

The Samsung logo consists of the word "SAMSUNG" in white, bold, uppercase letters, centered within a blue, horizontally-oriented oval shape.

**SAMSUNG**

QUARTZ DATE

**MAXIMA ZOOM 105**

ENGLISH/ESPAÑOL(S)

**SAMSUNG CAMERA**

Thank you for purchasing the SAMSUNG MAXIMAZOOM 105. Please read this instruction-manual carefully before using the camera.

## PREPARATION

- Note ..... 7
- Replacing the battery ..... 8
- Battery check ..... 8
- Film loading ..... 9
- Strap Attachment ..... 11

## PHOTOGRAPHING

- Using the Camera ..... 12
- Taking Pictures ..... 13
- Using the Focus Lock ..... 15
- Using the View Finder ..... 16
- Rewinding the Film ..... 17

## APPLICATION

- Macro photography ..... 19
- Super macro photography ..... 20
- Backlight control ..... 21
- Red-eye reduction : pre-flash ..... 22

- Fill-in/off flash ..... 23
- Bulb/Bulb-Sync ..... 24
- Exposure compensation ..... 25
- Continuous shooting ..... 25
- Fuzzy mode ..... 26
- Portrait zoom mode ..... 26
- Step zoom mode ..... 27
- Self-timer shooting ..... 28
- Interval shooting ..... 29
- Multi-exposure shooting ..... 30
- Landscape (Infinity) mode ..... 31

## CHECK

- Date imprinting (MAXIMA ZOOM 105 Q.D. only) ..... 34
- Care and storage ..... 36
- Things to be careful of ..... 36
- Troubleshooting ..... 37
- Specifications ..... 38

## MAIN FEATURES

---

1. Fuzzy Mode.(intelligent shooting)
2. Portrait zoom
3. Step zoom
4. Red-eye reduction
5. Auto, Fill-in, Off flash
6. Macro, Super macro photography
7. Bulb, Bulb-sync
8. Exposure compensation
9. Continuous shooting
10. Interval shooting
11. Single or multiple self-timer shooting
12. Multi-exposure shooting
13. Landscape (infinity) photography
14. Auto power off
15. Date imprinting (MAXIMA ZOOM 105 Q.D. only)

- \* Prior to returning camera to the place of purchase, please check lithium battery by inserting a new fresh battery (S).
- \* Always have a fresh battery available. Don't miss your best shot.

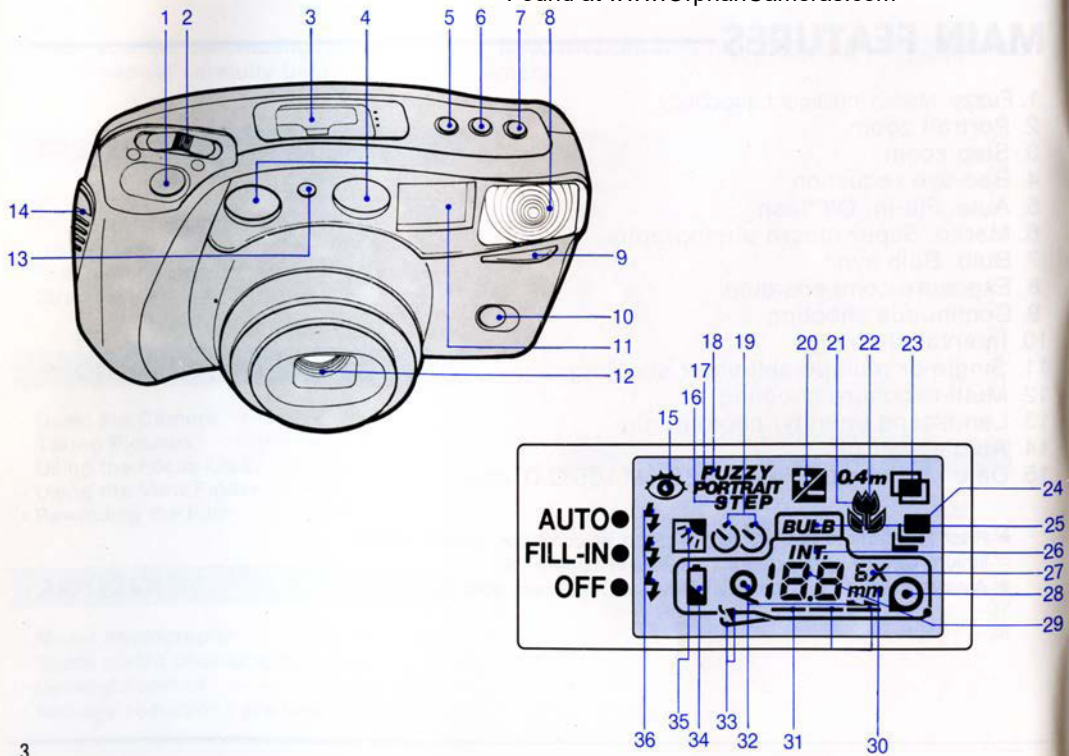

## NAMES OF PARTS

---

1. Shutter button
2. Zoom switch
3. LCD panel
4. Autofocus windows
5. Exposure mode selection button
6. Shooting mode selection button
7. Set button
8. Flash
9. Self-timer lamp
10. Landscape button
11. Finder window
12. Lens and Lens cap
13. Exposure sensor
14. Strap holder
15. Red-eye reduction mode
16. Step zoom mode
17. Portrait zoom mode
18. Fuzzy zoom mode
19. Self-timer (single/Multiple) mode
20. Exposure compensation mode
21. Super macro mode
22. Macro mode
23. Multi-exposure mode
24. Continuous shooting mode
25. Bulb/Bulb-Sync
26. Interval shooting mode
27. Exposure compensation EV display  
Film counter EX display
28. Film cartridge
29. Exposure counter  
Interval/Bulb time display  
Focal length indicator
30. Minute
31. Film winding indicator
32. Film rewinding indicator
33. Back cover open indicator
34. Battery condition indicator
35. Backlight control mode
36. Flash mode indicator

### LCD PANEL

NAME OF PARTS

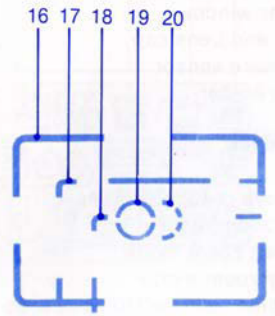
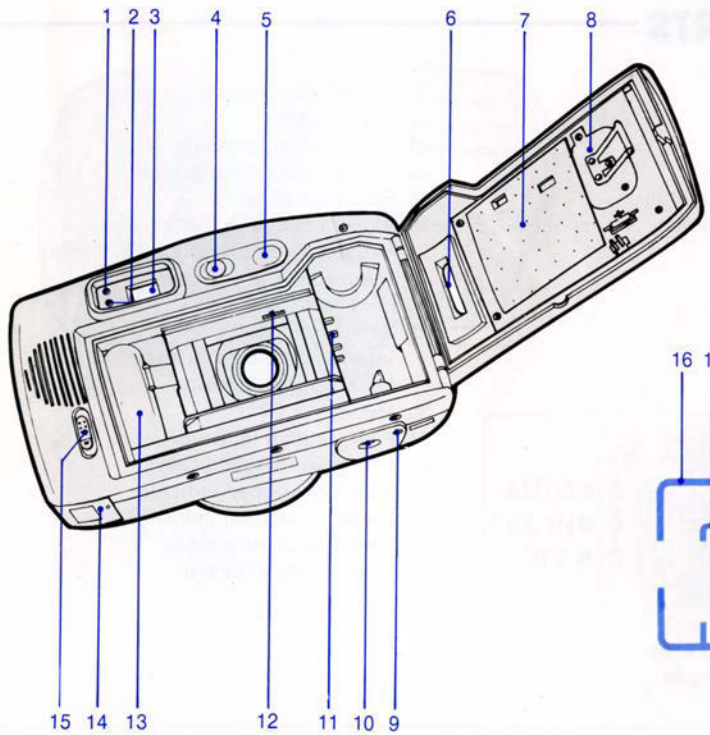

1. Autofocus indicator(Green LED)
2. Flash indicator(Red LED)
3. Viewfinder eyepiece
4. Macro/Super Macro button
5. Power ON/OFF button
6. Film window
7. Film pressure plate
8. Date back battery chamber cover
9. Mid-Roll rewind button
10. Tripod socket
11. DX contacts
12. Sprocket
13. Spool
14. Battery chamber cover
15. Back Cover release knob
16. Picture area frame
17. Macro area frame
18. Super macro area frame
19. Auto focus frame
20. Macro auto focus frame

## NOTE

---

- This camera will not work without batteries.
- Use two 3V lithium batteries (CR-123A or DL-123A).
- The lens cap automatically opens when the ON/OFF button is turned on. Do not open the lens cap with your fingers.
- when the camera has no film, the shutter functions but winding and rewinding does not.

### **The shutter does not function in following circumstances.**

- When the camera has no battery or when the battery is almost exhausted.
- When the lens cap is closed.
- When the zoom button is operating or when the film is winding or rewinding.
- When the film remains in the camera after rewinding.
- When the flash is being charged.

★ This camera is controlled electronically by a built-in microcomputer. Although unlikely, it may fail to operate under certain circumstances in which there is strong static electricity. In such cases, please take out the lithium battery and put it back into the battery chamber again after 2-3 minutes.

## REPLACING BATTERIES

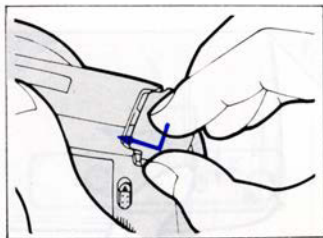
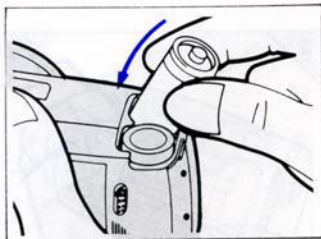
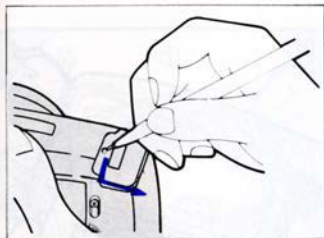

- Open the battery chamber cover by pressing the hole with a pin and then push it as shown.
- Remove the old batteries, insert new batteries and be sure to place in the correct position.

## BATTERY CHECK

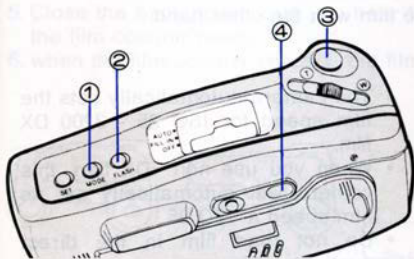

You can check the battery by pressing either ①, ②, ③ when the power button ④ is turned on.

|  |   |
|--|---|
|  | <ul style="list-style-type: none"> <li>• Normal operation.</li> <li>• If the battery check indicates half way, it is time to change the battery. You can still shoot about 3 more rolls of film after this indicator shows.</li> </ul>  |
|  | <ul style="list-style-type: none"> <li>• Replace the battery</li> <li>(1) Do not take out the battery while using the camera. When replacing the battery close the lens cap.</li> <li>(2) Even when the battery performance is reduced by low temperatures, the battery will function normally again when the temperature returns to normal.</li> </ul> |

# FILM LOADING

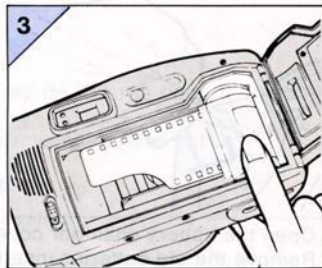
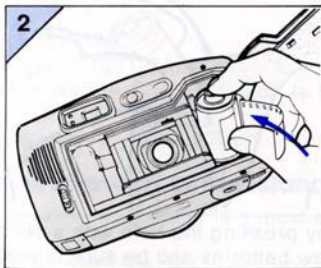
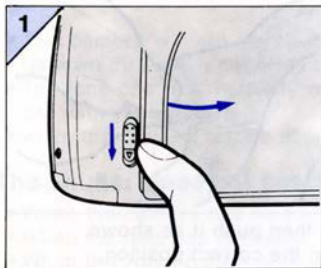

1. Open the cover by sliding the back cover release knob in direction of arrow.
2. Insert a roll of film in the film chamber.
3. Hold the film roll with one hand and pull out the end of the film with the other hand.

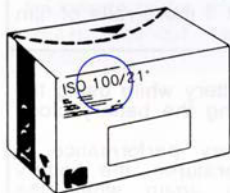

- The camera automatically sets the film speed for ISO 25 - 3200 DX film.
- When you use non-DX film, this camera will automatically set its film speed at ISO 25.
- Do not load film in the direct sunlight.

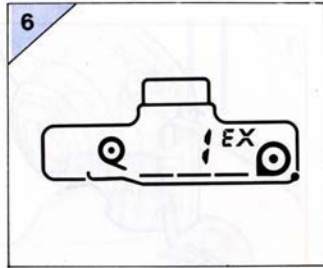
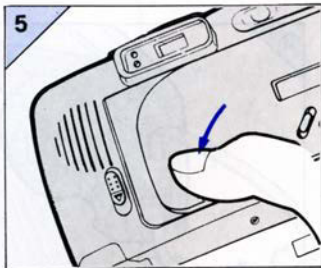
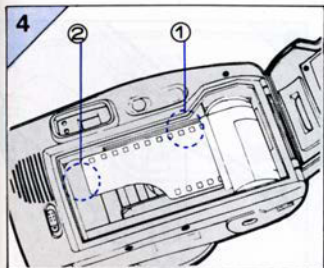

4. Pull the end of the film to the film tip position in figure 4, if you have pulled out the film too far, rewind the film a little. The film should lie flat.
5. Close the back cover until you hear the "Click" sound, the film will automatically advance until the film counter reads "1".
6. when the film counter reads 1, the film winding stops automatically.

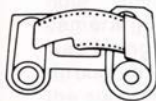

×

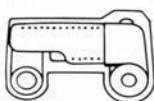

○



- If DX - film is improperly loaded, "E" mark will blink as illustrated, (In case of ISO 25 film mark is not shown), then take out the roll of film and load again.

## STRAP ATTACHMENT

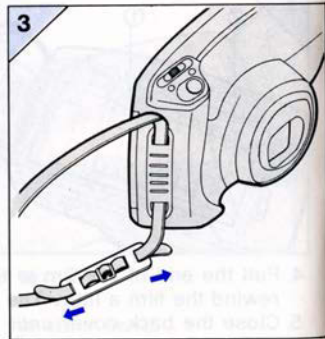
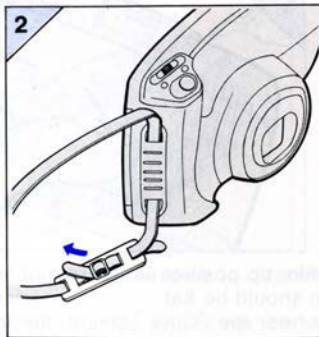
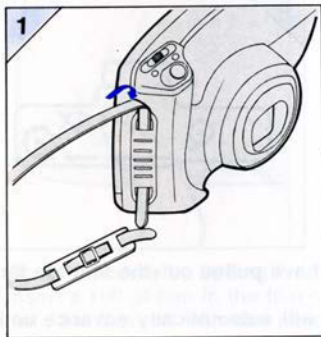

Please adjust the camera strap as illustrated.

# USING THE CAMERA

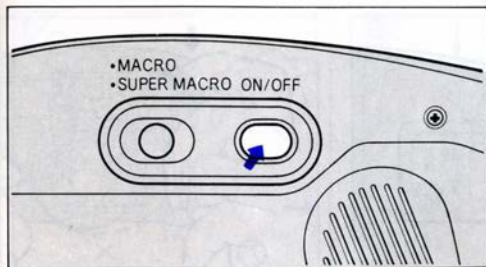

- Press the ON/OFF button to turn power on. The lens opens and LCD indication appears.
- The lens cap closes and power switches off automatically in 3 minutes if you do not use camera.
- If you press the ON/OFF button within 1 hour after automatic shut-down, the camera goes back to the same mode that was being used previously. While looking through the viewfinder, aim the camera at the subject by operating the zoom switch.

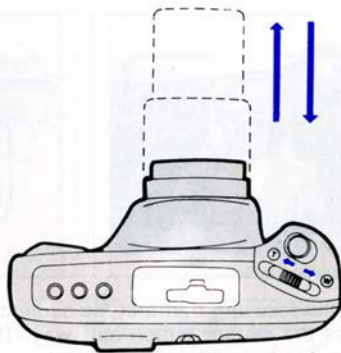

- By operating the zoom switch, the lens moves in and out. When the lens moves from wide mode to tele mode, LCD panel shows you following order : 38, 45, 50, 60, 65, 75, 80, 90, 95, 105mm.
- The shutter release locks during zooming.

## TAKING PICTURES

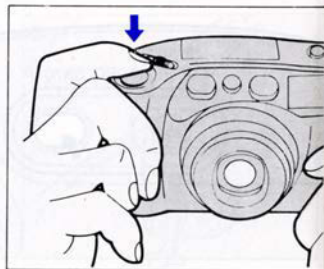
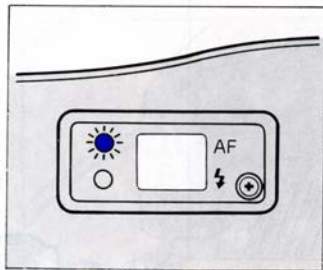

- Aim the focusing frame at the subject.
- Press the shutter button half way. The lens starts focusing itself and the green lamp turns on when it is focused on the subject.
- If the subject is within 1m from the camera, the green lamp blinks quickly and the shutter locks. In this case, you can still take pictures just by using Macro mode or Super Macro mode.
- Press the shutter button all the way to take pictures.
- Press the shutter button carefully to avoid camera shake.

★ After taking pictures, close the lens cap. This will protect your lens, prevent unintended shots and help your battery to last longer.

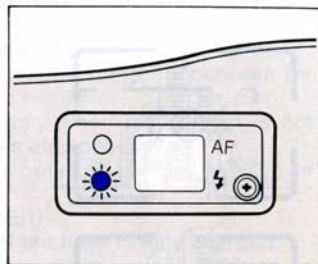
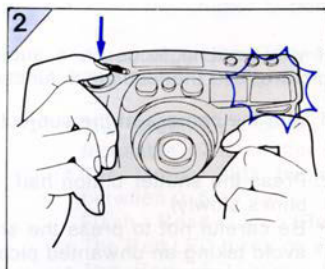
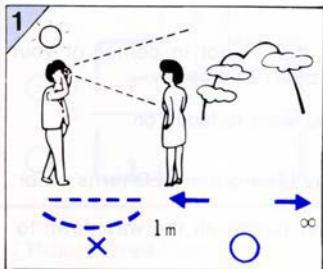

1. Any subject between 0.6m - ∞ is focusable

- Ordinary mode : 1m (3.3 ft) - ∞
- Macro mode : 0.6m (2 ft) - 1m (3.3 ft)
- Super Macro mode : 0.4m (1.3 ft)

2. Flash automatically fires to provide correct exposure in low light.

- The Red LED turns on when the flash is fully charged.
- The Red LED blinks slowly when using a tripod is recommended to avoid camera shake.
- The Red LED blinks rapidly when the flash is not charged yet. (Shutter locks automatically)

| Film   | 38mm                 | 105mm                | MACRO               |
|--------|----------------------|----------------------|---------------------|
| ISO100 | 1~5m<br>(3.3-16.5ft) | 1~3m<br>(3.3-9.9ft)  | 0.6~1m<br>(2-3.3ft) |
| ISO200 | 1~7m<br>(3.3-23ft)   | 1~4.2m<br>(3.3-14ft) | 0.6~1m<br>(2-3.3ft) |
| ISO400 | 1~10m<br>(3.3-33ft)  | 1~6m<br>(3.3-20ft)   | 0.6~1m<br>(2-3.3ft) |

★ If you block the autofocus window with your fingers or with your hair when taking pictures, your subject will be out of focus.  
 ★ To take clear pictures with the flash, refer to the chart above.

## USING THE FOCUS LOCK

---

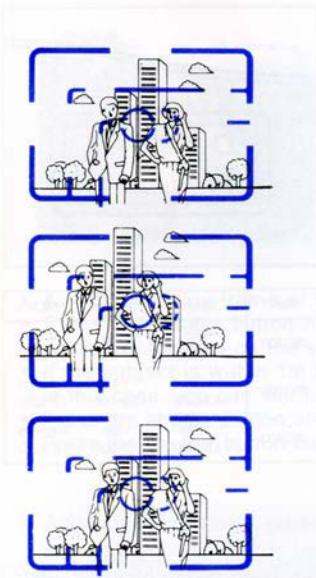

If you want to focus on a subject that is not in center of your picture, use the focus lock function described below.

1. Aim the camera at the subject you want to focus on.
  2. Press the shutter button half way (The green LED turns on or blinks slowly)
    - Be careful not to press the shutter button all the way down to avoid taking an unwanted picture.
  3. Keeping the shutter button depressed, recompose your picture as desired.
    - Hold the camera steady and gently press the shutter button fully down.
    - The focus lock can be released by lifting your finger from the shutter button.
- ★ Some subject are hard to focus on.
- ① Items that have a bright light in the background. (complete back-light)
  - ② Fireworks, smoke, or similar floating subjects.
  - ③ Shining or glossy surfaces such as a car body or the surface of water.
  - ④ Subjects behind glass windows.

# USING THE VIEW FINDER

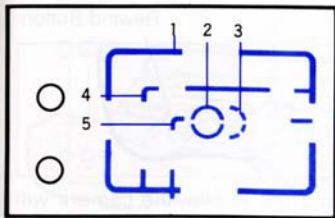

1. Picture Area Frame
2. Auto-Focus Frame
  - The auto-focus is set for the picture area inside this frame
3. Macro Auto-Focus Frame
  - This makes it possible to use auto-focus for close up shots.
4. Macro area frame
5. Super macro area frame

- Press the shutter button half way to check the indication lamp.
- Auto Focus Lamp (Green Led)
  - The Green LED turns on when the subject is between 1m -  $\infty$
  - The Green LED blinks rapidly when the subject is not focusable - The shutter locks automatically
  - The Green LED blinks slowly when the subject is between 0.6m - 1m.
- Flash - Ready Lamp (Red LED)
  - The Red LED turns on when the flash is fully charged.
  - The Red LED blinks slowly when using a tripod is recommended to avoid camera shake.
  - The Red LED blinks rapidly when the flash is not charged yet. (Shutter locks automatically)

# REWINDING THE FILM

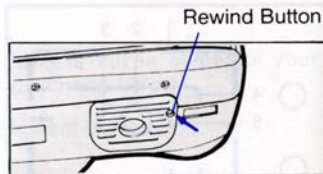
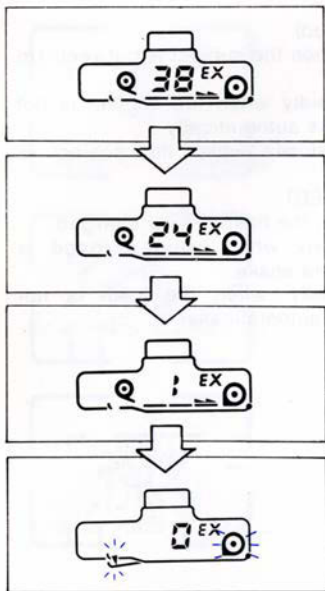

- After taking all the pictures on a roll of film, the camera will automatically rewind the film. The motor stops when the rewinding is completed.
- Mid-roll rewinding : To rewind the film in the middle of a roll, press the rewinding button.
- To stop the film rewinding, press the shutter button.
- Make sure that the film rewinding is complete, then open the back cover, and take out the film.

## NOTE

- If the motor stops before the LCD shows "0", replace the battery.  
Do not open the back-cover until the battery is replaced.

★ If you press the shutter button during film rewinding, the rewinding stops, and starts again when you lift your finger from the shutter button.

# SPECIAL FEATURES

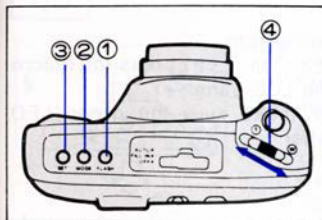

1. Exposure mode : You can select the Exposure mode by pressing the FLASH button (1)

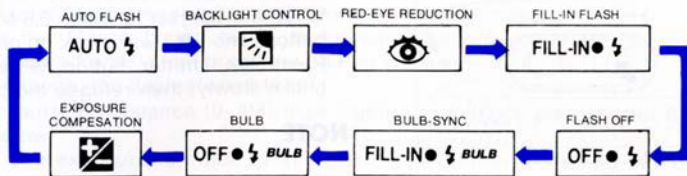

2. Shooting mode : You can select the Shooting mode by pressing the MODE button (2).

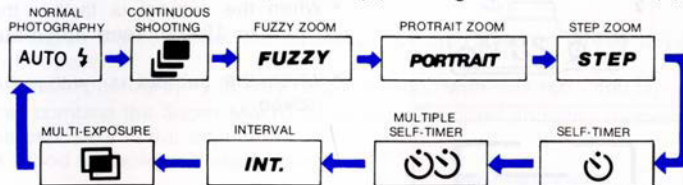

- When pressing the FLASH button or MODE button, the modes change in the sequence shown above.
- To adjust the settings of Bulb/Bulb Sync timer, Exposure compensation, Step ZOOM, Multiple Self-timer, and Interval shooting, move the zooming switch to Tele(T) or Wide (W) while keeping the SET button ③ pressed.
- To release the selected mode, press the ON/OFF button, then the power will be off. (In cases of Bulb mode and Bulb-Sync mode, the mode is released by pressing the ON/OFF button once, and the power is off by pressing the ON/OFF button once more.)



## MACRO PHOTOGRAPHY

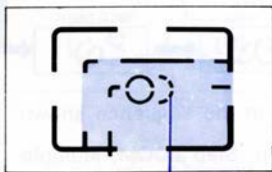
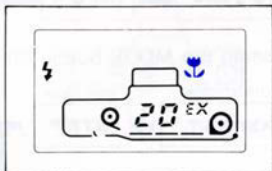
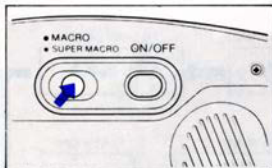

Macro Auto Focus Frame

- Use this mode to take close-up photographs.
- When the subject is within 0.6 M (2 ft)-1M (3.3 ft), press the Macro button. The (🌷) will show up on the LCD panel.
- Press the shutter button half way, make sure the green LED blinks slowly, then release the shutter.

### NOTE

- When the Macro autofocus frame is outside of your main subject, use the "FOCUS LOCK" on page 15.
- When the subject is farther than 1M (3.3ft) away, the lens will move to 105mm lens automatically upon pressing the shutter button.
- When the subject is within 0.6M (2 ft), the shutter is to be locked.



# SUPER MACRO PHOTOGRAPHY

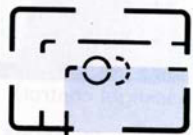
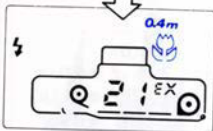
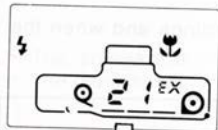

- Use Super Macro mode to take picture at extremely close range.
- Press the Macro button twice, make sure the subject in the Super macro area frame, then press the shutter button.  
In this mode, the flash always fires.
- ★ To measure the distance (0.4M) from camera to subject, please refer to the below.
- After one exposure is made in this mode, the ordinary shooting mode is automatically restored.

## NOTE

- On the Super Macro mode, the autofocus function and the Green LED does not operate.
- Super Macro photography is only recommended with ISO 100 - 400 film.
- You can combine the Super Macro mode with the other shooting modes, but the exposure is not adjustable.
- Use a tripod to avoid camera shake.

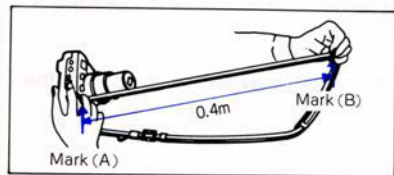

★ To measure the distance (0.4M) from camera to subject, use two marked points on the strap by aligning the strap between the camera and the subject, as shown in the illustration.



## BACKLIGHT CONTROL

- Use this mode when your subject is in low light compared with the surroundings and when the distance is too great to use the flash.

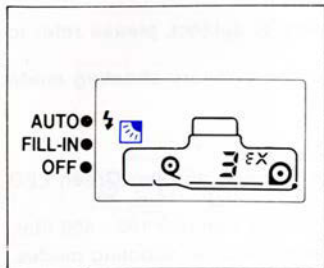

〈Before Backlight control〉



〈After Backlight control〉

- This will balance the dark areas of your subject with strong background light. (Exposure compensation : +1.5EV)

### NOTE

- Note that the reflection of strong backlight such as direct sunshine may cause flares on the picture.
- Be careful to avoid the direct sunlight on the lens.

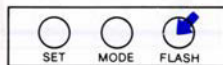

## RED-EYE REDUCTION : PRE-FLASH

- The red-eye phenomenon is most likely to occur when you take portrait pictures in very low light.
- The pre-flash can significantly reduce the "red-eye" in flash portraits.

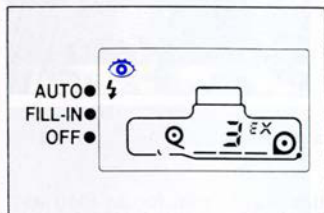

〈AUTO FLASH〉



〈RED - EYE REDUCTION〉

### NOTE

- The flash fires two times in sequence, so be careful not to shake the camera between flashes.

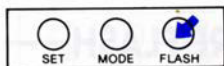

FILL-IN ● ⚡

## FILL-IN FLASH

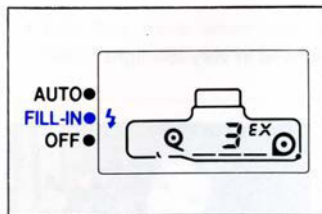

<AUTO>



<FILL-IN>

- When the surrounding light conditions are too strong for the auto flash to engage, the fill-in flash allows you to expose the subject properly.
- You can use this mode for night shots.

In this mode, the flash fires to light the main subject and the shutter stays open for as long as needed—up to 1/3 second to provide for adequate background exposure. (Use a tripod to avoid camera shake)



OFF ● ⚡

## FLASH OFF

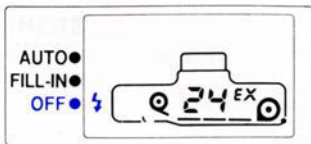

- Use this mode when you want to take pictures of sunsets or interiors without a flash.

• Use a tripod to avoid shaking the camera when you see the red LED blink quickly.

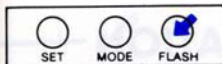

**BULB**

**BULB : B SHUTTER**



BULB-SYNC MODE, 2 SEC WITH ISO 100



BULB MODE, 8 SEC WITH ISO 100

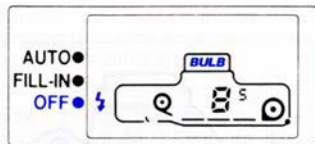
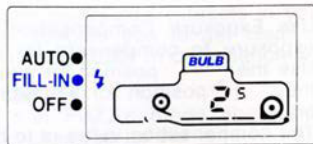
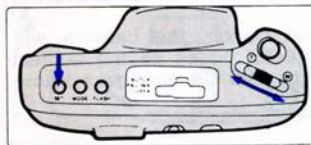

- Use the Bulb mode for time exposures of subjects such as firework and night scenes. The shutter remains open for as long as the shutter button is depressed.
- BULB-SYNC. (Bulb with FILL-IN FLASH) : This mode is useful to take portraits in low light conditions. This allows the main subject to be illuminated by flash and the background exposed with available light.
- ★ Bulb-timer (1, 2, 4, 8, 15, 30, 60 sec. )  
In Bulb or Bulb-Sync mode, the shutter speed can be set between 1sec. and 60sec.  
Move the zooming switch to wide(W) or tele(T), while keeping the SET button depressed.

**NOTE**

- To avoid camera shake, use a tripod.  
Use this mode only in low light, otherwise the pictures will be overexposed.
- The Bulb/Bulb-Sync mode can be released by pressing the ON/OFF button. (To cut the power, press the ON/OFF button once more. )

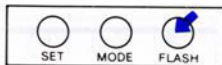

## EXPOSURE COMPENSATION

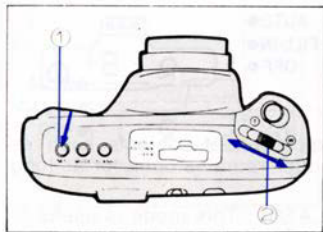

- Use Exposure Compensation to manually adjust the level of exposure to compensate for overall brightness or darkness.
- Use the “+” position for situation with bright backgrounds, or the “-” position for situations where the main subject is too bright.
- The compensation value is to be set by the moving the zooming switch (2) to tele(T) or to wide (W) while keeping the SET button (1) depressed.

The range of compensation is between 3EV and + 3EV in gradations of 0.5EV.

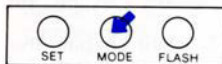
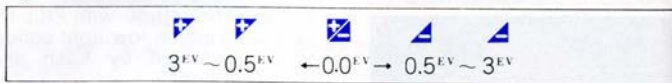

## CONTINUOUS SHOOTING

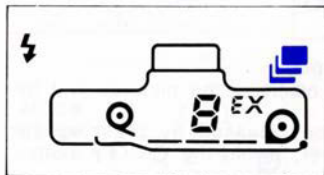

- Use this mode to take a sequence of pictures of a moving subject.
- As long as you press the shutter button, the camera will continue to take pictures. The camera focuses on the subject frame by frame during this operation, so the autofocus frame should be kept on the subject.

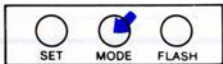

## **FUZZY FUZZY : INTELLIGENT SHOOTING**

- To avoid camera shake and under-exposed subjects in your pictures, use FUZZY mode. The built-in intelligent microcomputer enables you to get clear and properly exposed pictures by controlling the focal length, flash and shutter in compliance with the surrounding situation.

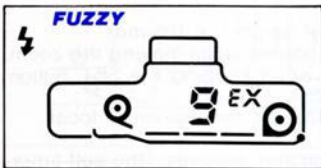

### **NOTE**

- In FUZZY mode, the subject size of your picture may be changed as the lens will automatically adjust to provide the optimum photographic conditions.

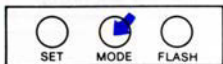

## **PORTRAIT PORTRAIT ZOOM**

- Use Portrait zoom mode to maintain a constant size within the frame, even though the distance to the subject may vary. (Example : Head-and shoulders portrait)

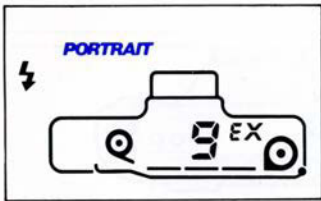

- Position your subject in the center of the viewfinder and press the shutter button half-way. Then the zoom will operate automatically to attain the desired shot.
- Press the shutter button fully to take the picture.



〈Normal mode〉



〈Portrait zoom〉

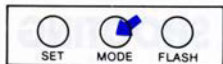

## **STEP** **STEP ZOOM**

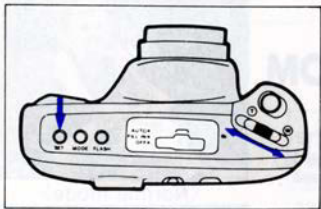
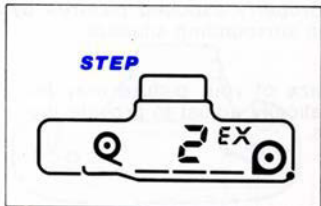

- Use Step Zoom to take a number of pictures of the same subject using different focal lengths. Up to ten different shots can be made.
- Firstly, set the lens to max focal length i. e 105 mm.
- You can choose the number of photos while moving the zoom switch to tele (T) or wide (W) while keeping the SET button depressed.
- The number of photos depends on the maximum focal lengths chosen.
- The first shot will be taken after ten seconds. (the self-timer lamp turns on for 7 seconds and blinks for 3 seconds.) From the second shot, the intervals between shots is 4 seconds.



## SELF-TIMER

- You can get yourself into the picture by using the self-timer.
- After selecting the self-timer mode by pressing the MODE button, press the shutter button.
- The self-timer lamp turns on for 7 seconds and blinks for 3 seconds before the shutter is released.

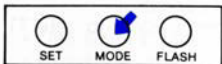
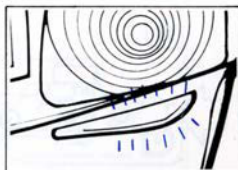
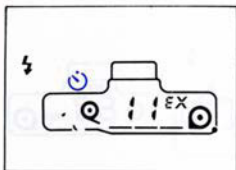

## MULTIPLE SELF-TIMER

- You can choose the number of photos (2 - 10 exposures) with the zoom switch while keeping the SET button depressed.
- The self-timer lamp turns on for 7 seconds and blinks for 3 seconds on the first shot.
- From the second shot, the interval between shots is 4 seconds.

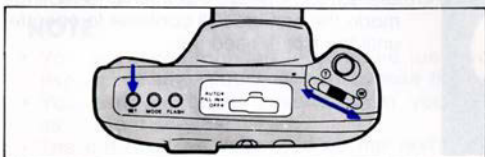
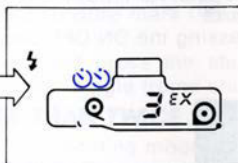
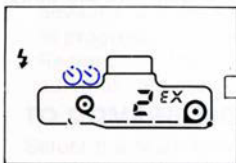

- \* When using flash, the shooting interval become longer due to the flash recharging.

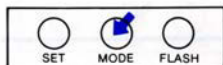

**INT.**

## INTERVAL SHOOTING

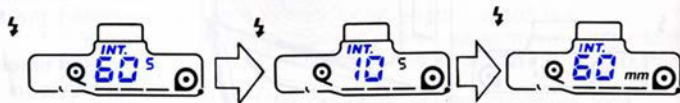
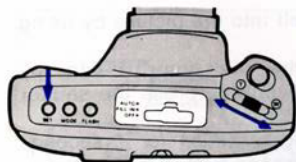

- Use the Interval Shooting mode to take pictures automatically over a chosen period.
- You can choose the interval time (10 seconds - 60 minutes) by moving zoom switch to tele(T) or wide (W) while keeping the SET button depressed.
- When you press the shutter button after setting the interval time, the lens retracts into the body and the lens cover closes, then the count-down starts.
- You can release the Interval Shooting mode by pressing the ON/OFF button.



Unless you release the Interval Shooting mode, the camera will continue to operate until the film is used up.

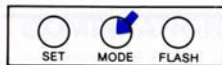

## MULTI-EXPOSURE SHOOTING

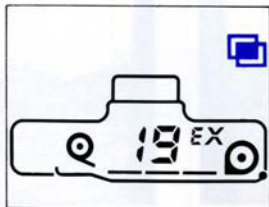

- Use Multi-Exposure shooting mode to combine multiple images on a single frame.
- Press the shutter button after selecting the multi-exposure shooting mode (☐). The film will not advance and the Multi-Exposure mark (☐) will blink to indicate that multi-Exposure Shooting is in progress.
- Recompose the frame, and press the shutter button for the second shot, then the film will automatically advance and Single frame shooting mode will be restored.

### TO COMBINE MORE THAN TWICE :

Select the Multi-Exposure Shooting mode again before the second exposure, and those succeeding it. After the last exposure in the sequence, the film will advance to the next frame.

### NOTE

- You are recommended to combine just two exposures on a frame because too many multiple exposures may cause to overexpose the picture.
- You can get better results when you use Multi-Exposure mode in the dark background, such as in night scenes.
- The date will be imprinted on the last exposure. (AF-ZOOM 1050 Q. D.)



## LANDSCAPE MODE : INFINITY MODE

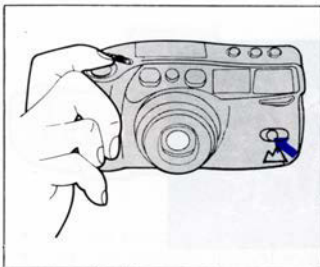

〈Normal mode〉















〈Landacape mode〉

- Use landscape mode to photograph distant subjects through the window.
- Press the shutter button while keeping the landscape button (  ) depressed. (When you take off your finger from the landscape button, the mode will be released.)

### NOTE

- On landscape mode, the green LED does not turn on when you press the shutter button.
- On landscape mode, the camera is set to OFF-FLASH. (You can't not select any other exposure mode.)

# 〈COMBINATION CHART OF EXPOSURE AND SHOOTING MODE〉

| A<br>B           |   | ×  | ×   | ×   | F32<br>○  | ×   | ×  | ×          | ×   | MACRO | SUPER<br>MACRO |  |
|------------------|---|--|---|---|---|---|--|------------|---|-------|----------------|--|
|                  |   | ○  | ○   | ○   | ○   | ○   | ○  | ○          | ○   |       |                |  |
|                  |   | EXPOSURE MODE  |   |   |   |   |  |            |   |       |                |  |
|                  |   | AUTO  |   |   | FILL-IN  | OFF  | BULB  | BULB       |  |       |                |  |
| SHOOTING<br>MODE | NORMAL  | ○  | ○   | ○   | ○   | ○   | ○  | ○          | ○   | ○     | ○              |  |
|                  |  | ○  | ○   | ○   | ○   | ○   | T.Set<br>□   | T.Set<br>□ | ○   | ○     | ○              |  |
|                  | FUZZY   | ○  | ◇   | ○   | ◇   | ◇   | ×  | ×          | ◇   | ×     | ×              |  |
|                  | PORTRAIT  | ○  | ○   | ○   | ○   | ○   | ○  | ○          | ○   | ×     | ×              |  |
|                  | STEP  | ○  | ○   | ○   | ○   | ○   | △  | △          | ○   | ×     | ×              |  |
|                  |  | ○  | ○   | ○   | ○   | ○   | △  | △          | ○   | ○     | ○              |  |
|                  |  | ○  | ○   | ○   | ○   | ○   | △  | △          | ○   | ○     | ○              |  |
|                  | INT.  | ○  | ○   | ○   | ○   | ○   | △  | △          | ○   | ○     | ○              |  |
|                  |  | ○  | ○   | ○   | ○   | ○   | ○  | ○          | ○   | ○     | ○              |  |

## THE MEANINGS OF SYMBOLS IN THE CHART.

- ⊙ : Ordinary photography
- : Combination is possible. As shown in the table, exposure and shooting combinations are available in various ways.
- △ : Combination is possible. When the Bulb-Timer is not used, the shutter is released at a shutter speed of approx 1/2 second.
- : Combination is possible, when the Bulb-Timer is used.
- ◇ : Combination is possible, but the shutter is to be locked in the low light condition.
- × : Combination is impossible.

**DATE IMPRINTING(MAXIMA ZOOM 105 Q.D ONLY)**

MODE SELECT SET

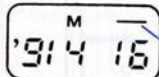
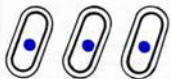

Print indicator

Year-Month-Day

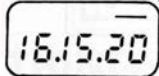

Day-Hour-Minute

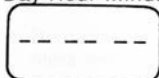

No imprinting

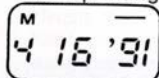

Month-Day-Year

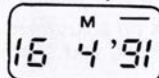

Day-Month-Year



Dating Zone

- Pressing the button changes modes in the sequence shown above.
- Through the finder, you check and adjust the position where the date imprinting will appear on the picture.
- When a date is imprinted on a particular exposure, the print indicator will blink for two to three seconds in the liquid crystal display.

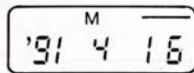

Choose the dating mode by pressing the MODE button.

MODE SELECT SET

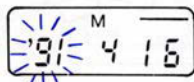

Choose the part to be corrected by pressing the SELECT button.

MODE SELECT SET

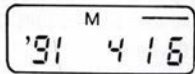
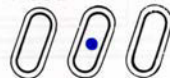

Adjust to the desired date and time by pressing the SET button.

MODE SELECT SET



- The numbers will run through quickly if you continue to depress the button.
- ★ Use a round-pointed ballpoint pen to avoid damage the button.

## REPLACING THE BATTERY

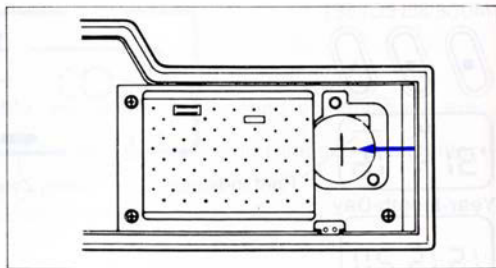
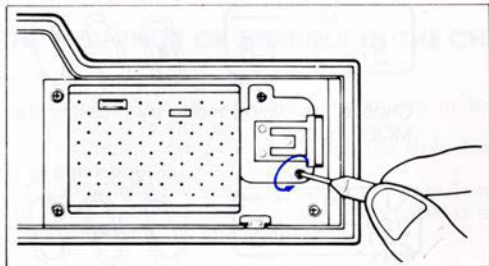

Open the camera's back cover.

- Open the battery chamber cover by depressing the battery chamber button.
- Take out the old battery and insert a fresh one, with the plus (+) side up.

Power source : One 3V lithium battery (JIS CR 2025)

- Battery life : approx. 3 years.
- ★ When the display becomes too dim to read, the battery should be replaced.

- ★ The date may be difficult to read if it is imprinted on bright, white or nonuniform area.
- ★ This unit is designed for use between 50° and -10°C (approx. 120° and 15°F). At temperatures above or below this range, the date may be difficult to read.
- ★ MAXIMA-ZOOM 105 Quartz Date is equipped with an automatic calendar which requires no adjustment through the year 2019. Once set, calendar automatically advances the date, adjusting for long and short months and leap years.

## CARE AND STORAGE

---

- If your camera needs cleaning, wipe it off with a soft cloth.
- The lens should be cleaned only with the lens cleaning tissue and fluid.
- Do not allow your camera to make contact with sand or water.
- Keep your camera in a dry, cool place that is free from humidity and dust. Never put it in hot places such as in a parked car, or leave it in direct sunlight.
- Avoid using alcohol or other chemical solvents on the camera body.
- The temperature range in which the camera functions properly is 50°C to -10°C (122°F to 14°F)

## THINGS TO BE CAREFUL OF

---

1. Be careful to keep from spilling anything on the lens or light meter cells. It is a good idea to keep your camera lens cap closed whenever the camera is not in use.
2. If you have trouble with your camera please take it to a dealer or distributor, or back to the store where you bought it. Do not try to take the camera apart or to repair it yourself. The camera contains a high voltage circuit that could be hazardous.
3. Keep your camera safe from sudden shocks or vibration. If you drop your camera it is a good idea to have it checked before using it.
4. Using the camera when it is very cold hinders its performance. If you plan to take pictures when the temperature is below 45°F (7°C) take care to keep your camera and batteries warm.
5. Be particularly careful not to take your camera from a very cold place directly to a very warm place. This may cause moisture to condense on the inside of the camera.
6. Do not use your camera to take repeated flash pictures when the temperature is above 104°F (40°C).

## TROUBLESHOOTING

- If the scene in your picture area frame doesn't show on your pictures.

| Check Point  | Remedy                      | Page   |
|--|-----------------------------|--------|
| 1. It is within the range of the view frame ? (or the macro frame) | Read the Finder Mark again. | 13, 16 |

- If your picture is out of focus.

| Check Point   | Remedy   | Page       |
|---|--|------------|
| 1. Did you fix the object that You want to focus on ?                               | <ul style="list-style-type: none"> <li>• Read the instructions "Taking Pictures" again</li> </ul>  | 13, 15, 16 |
| 2. Was the Auto Focus window blocked by your finger or hair ?                       | <ul style="list-style-type: none"> <li>• Be careful not to block the Auto Focus Window.</li> </ul> | 14         |
| 3. Is the subject something which the Auto focus system can not properly focus on ? | <ul style="list-style-type: none"> <li>• Read the Note about Auto focusing again</li> </ul>        | 15         |

- If the Shutter does not function after pressing the Shutter Button.

| Check Point   | Remedy                                 | Page |
|---|--|------|
| 1. Is the Lens Cover completely opened ?                | Operate the Power Switch once.         | 12   |
| 2. Is the battery loaded correctly                      | Put the battery in a correct position. | 8    |
| 3. Has it been a long time since you used the battery ? | Change the battery                     | 8    |

# SPECIFICATIONS

|                   |   |
|-------------------|---|
| <b>TYPE</b>       | 35mm fully automatic lens shutter camera with built-in 38-105mm Zoom lens.  |
| <b>FILM</b>       | 35mm DX-coded film<br>* Film format : 24 x 36mm   |
| <b>LENS</b>       | Power zoom lens<br>38 - 105mm, F/4 - 10.5(9 elements 7 groups)  |
| <b>SHUTTER</b>    | Programmed AE electronic shutter (shutter speed : 1/3 - 1/250sec.)<br>Bulb and Bulb-Timer (1 to 60sec.)   |
| <b>FOCUSING</b>   | Active infrared automatic focusing with focus lock<br>* Focusing range : 1M(3.3 ft) - $\infty$<br>0.6M(2 ft) - 1M(3.3 ft) in Macro<br>0.4M(1.3 ft) fixed in Super Macro   |
| <b>EXPOSURE</b>   | Programmed automatic exposure control<br>* Auto exposure range (ISO 100 film)<br>AUTO/FILL - IN FLASH • EV9 - EV17 at Wide (38mm)<br>• EV12.75 - EV18.75 at Tele & Macro (105mm)<br>FLASH OFF • EV6 - EV17 at Wide (38mm)<br>• EV8.75 - EV18.75 at Tele (105mm) |
| <b>VIEWFINDER</b> | Albada type with Bright frame, Auto focus frame, Macro frame, Super Macro frame<br>* Field of view : 80%<br>* Magnification : 0.42 x (Wide position)<br>1.12 x (Tele position)  |

|                           |   |
|---------------------------|---|
| <b>FILM LOADING</b>       | Automatic loading, automatically advances to the first frame when the backcover is closed.  |
| <b>FILM ADVANCE</b>       | Automatic film advance.   |
| <b>FILM REWINDING</b>     | Automatic film rewinding when you reach the end of a roll. Rewinding stops automatically upon completion. (Mid-roll rewinding is also available.)   |
| <b>EXPOSURE COUNTER</b>   | Progressive type, displayed in LCD panel.   |
| <b>FILM SPEED SETTING</b> | Automatic setting with DX coded film ISO25 – 3200   |
| <b>FLASH</b>              | <p>Built-in zoom flash.</p> <ul style="list-style-type: none"><li>• Automatic flash activation in low light on "AUTO".</li><li>• Forced flash activation in daylight and slow speed synchro flash for night shots on "FILL-IN".</li><li>• Flash activation stop and slow shutter exposures for available light on "OFF".</li><li>• Pre-flash to reduce the red-eye phenomenon.</li></ul> <p>★ Flash working range (ISO 100 film)<br/>1M(3.3 ft) – 5M(16.5 ft) at Wide (38mm)<br/>1M(3.3 ft) – 3M(9.9 ft) at Tele (105mm)</p> <p>★ Flash recycling time : Approx. 3 sec.</p> |